

Maintenance advice:

Check the filter insert regularly and clean as and when necessary with a brush and water.

Guarantee:

3P Technik UK Ltd offers this product the guarantee required by law (from date of purchase)

3P Retention Filter XL

Rainwater filter for installation in rainwater tanks

Operating and assembly instructions

Item No. 1000675



3P Technik UK Ltd
Unit 9
Parc Teifi
Cardigan
SA43 1EW
contact@3ptechnik.co.uk
www.3ptechnikuk.com

Operating and assembly instructions

Retention Filter XL

How it works:

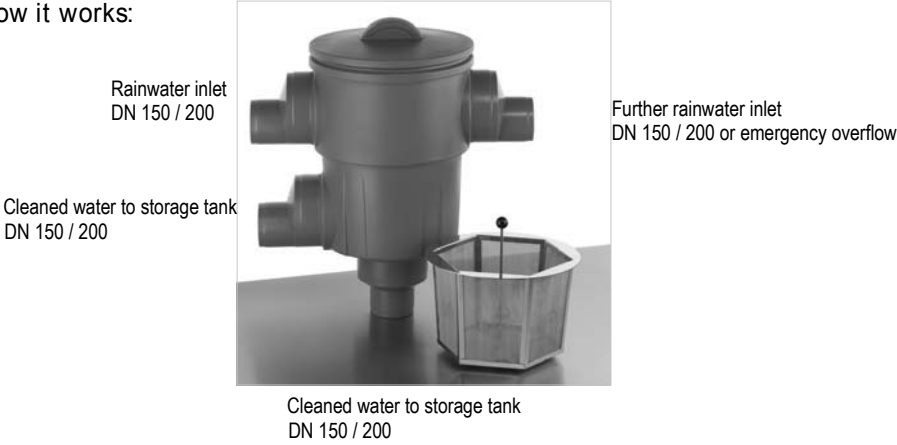

Operating and assembly instructions

Retention Filter XL

Please read and follow these instructions for the installation and handling of the 3P Retention filter XL rainwater filter.

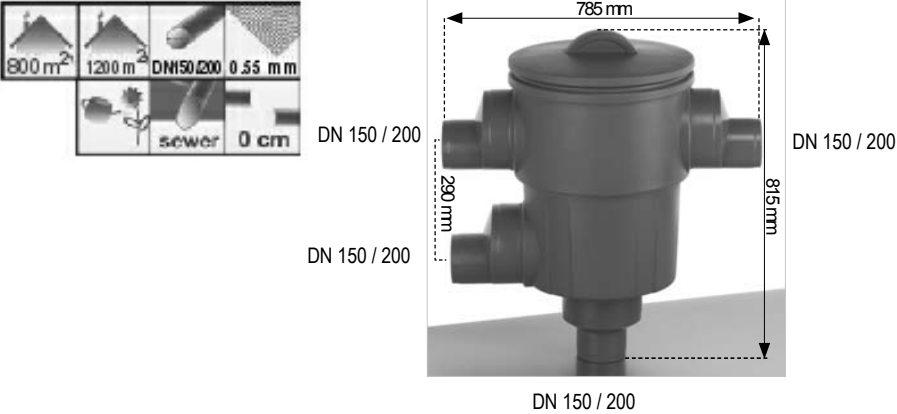

Installation in a rainwater tank - advice:

- Connect the inlet with plain pipe and the 3P Rapid connector, or a pipe socket.
- Connect the filter overflow with plain pipe and the 3P Rapid Connector, or a pipe socket, onto the overflow from the storage tank.
- Connect one of the filter outlets to the tank inlet pipe (vertical pipe) with DN 150/DN 200 pipe leading to a 3P Calmed Inlet. The 3P Calmed Inlet will help to support the filter in the tank. No other support is necessary.

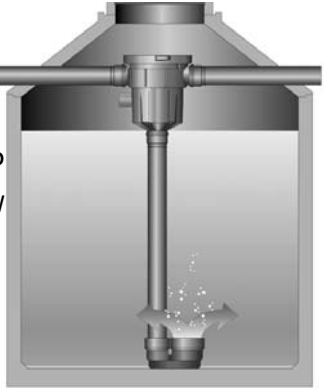

Installation advice:

Installation in rainwater tank

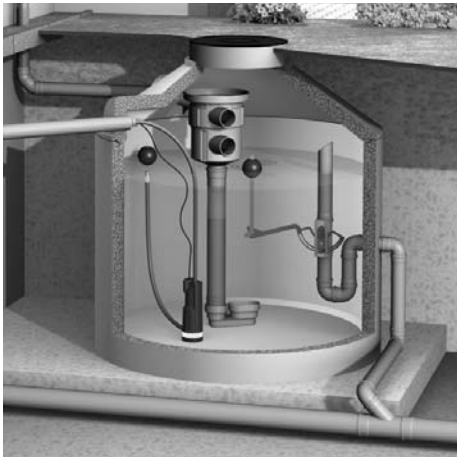

Installation in a soakaway

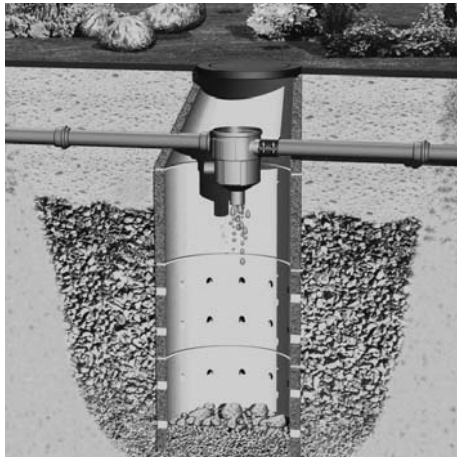

Recommended Accessories:

3P Overflow Sphon



Item No. 4000275 DN 150
Item No. 4000285 DN 200
Item No. 4000295 DN 250

3P Calmed Inlet DN 150 / 200 / 250



Item No. 4000150 DN 150
Item No. 4000155 DN 200
Item No. 4000160 DN 250