

# 3P Retention Filter

Rainwater filter for installation in rainwater tank

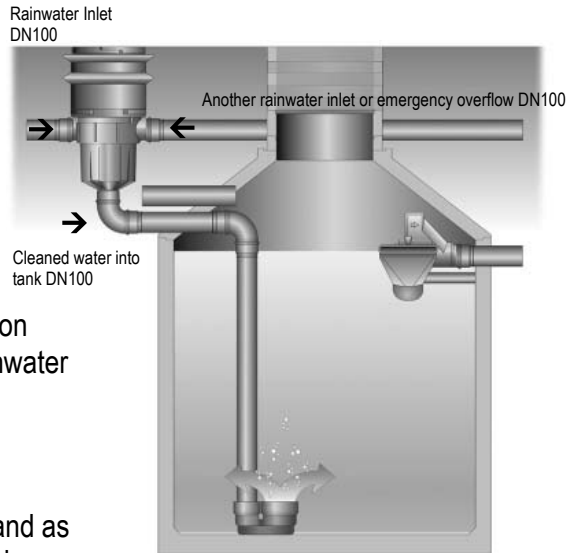

## 4.2. Underground Installation:

You can also install the 3P Retention Filter directly in the ground pre rainwater tank.

## 5. Maintenance advice:

Regularly monitor the filter insert, and as necessary remove this insert and clean sieve with water and brush.

## 6. Guarantee:

**3P Technik UK Limited** offers this product with guarantee regulated by law (from date of purchase).

## Installation instructions

Art.-Nr. 1000630



3P Technik UK Limited  
Unit 9 Parc Teifi  
Cardigan  
Wales  
SA43 1EW

contact@3ptechnik.co.uk  
www.3ptechnikuk.com

# Installation instructions

## 3P Retention Filter

Please read carefully the instructions for installation and handling of your rainwater filter, the 3P Retention Filter RF, and follow the advice.

### 1. Technical Data

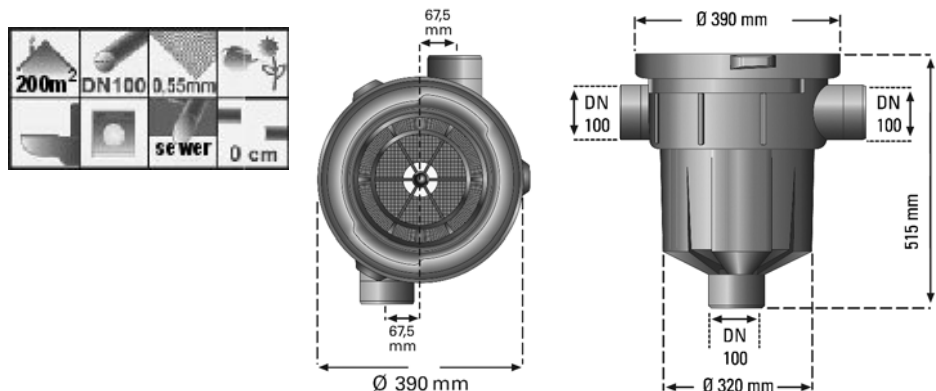

### 2. Installation advice:

Installation in **rainwater tank**.

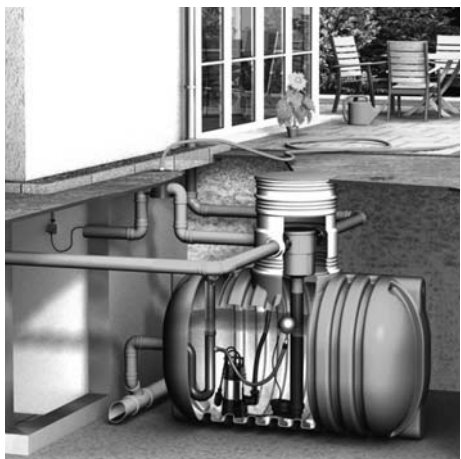

Installation in a **man hole or infiltration system**.

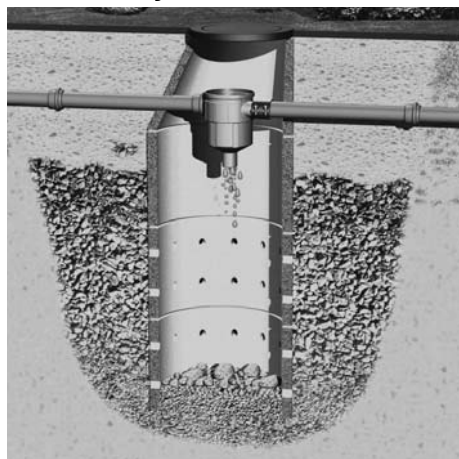

# Installation instructions

## 3P Retention Filter

### 3. How it works:

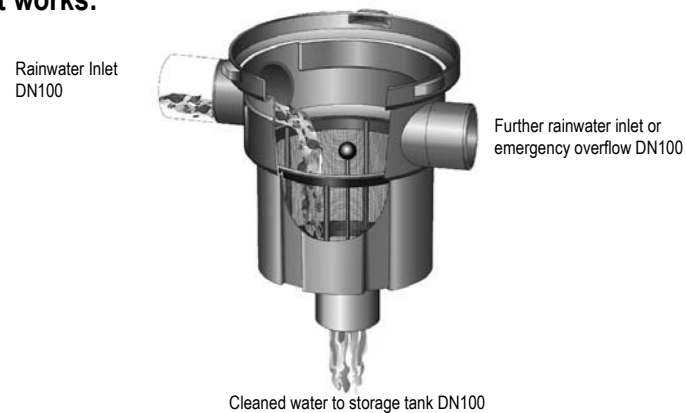

### 4. Installation in a rainwater tank

- Set up the inlet with pipe and connector, or pipe socket.
- Connect the filter overflow with pipe socket, or with the 3P Rapid Connector onto the overflow of the tank.
- Connect the filter outlet to the tank inlet pipe (vertical pipe) with DN100 pipe and a 3P Calmed Inlet. The 3P Calmed Inlet supports the Filter in the tank. No other support is necessary.

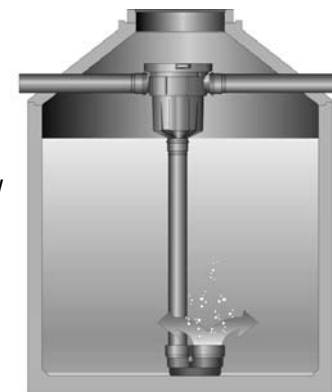

### 4.1. Recommended

3P Telescopic Extension Tube



Art.-Nr 1000560

3P Locking Lid



Art.-Nr 1000506

3P Rapid Connector



Art.-Nr 400075